

\*\* - DOES NOT INCLUDE WIRE HARNESS

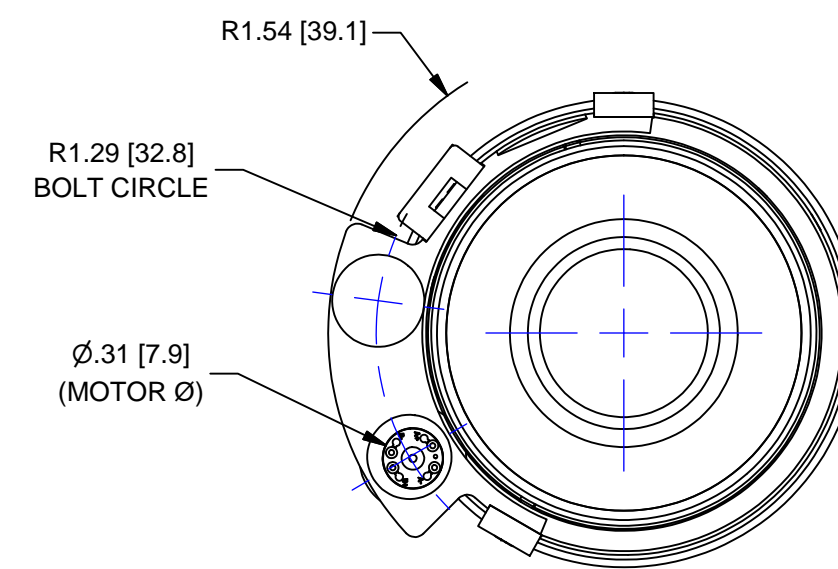

D-Sub Wiring Pinout	
D-Sub	PIN
1	A+
2	N/C
3	+5vDC
4	N/C
5	N/C
6	B-
7	A-
8	Far Limit
9	N/C
10	N/C
11	B+
12	Near Limit
13	Common
14	N/C
15	N/C

# OUTLINE



UNLESS OTHERWISE SPECIFIED DIMENSIONS ARE IN INCHES (MM) AND INCLUDE CHEMICALLY APPLIED OR PLATED FINISHES	PROPRIETARY AND CONFIDENTIAL THE INFORMATION CONTAINED IN THIS DRAWING IS THE SOLE PROPERTY OF NAVITAR. ANY REPRODUCTION IN PART OR AS A WHOLE WITHOUT THE WRITTEN PERMISSION OF NAVITAR IS PROHIBITED.	ASS'Y, Z7000, MTR ZOOM	
SCALE: 1:1	WEIGHT: N/A	DR BY: PB	CH BY: R. PODLENA
PROJECT #: E2814	DATE DR: 6/7/2011	DO NOT SCALE DRAWING	SIZE C
		1-19859	REV B
		SHEET 2 OF 2	