

Collimate LED Light IBF

Renewal
Power LED

Pioneer of the LED parallel ray light source: Collimate Light series has been renewed!

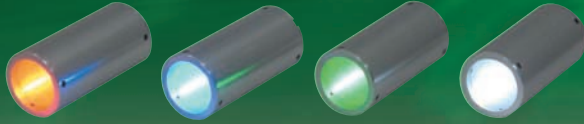

For conventional models, the profile of the irradiated area has color aberration and uneven luminance in the case of the white type. However, the new type Collimate LED Light irradiates uniform light onto all the area. "Parallel light with an area" which can irradiate light to tens of meters away with one LED has an ability "to cover all the area without scanning", which the laser light source can not achieve. Besides, since it can be handled more safely than the laser light source (laser class 2), it can be used as a substitute for the laser light source at inspection. Even if a light cannot be installed near a work in equipment, this light irradiates light "only to the required area from a long distance" while peripheral sensors are not affected because the light does not diffuse light like other light sources. In addition to white, red, blue, and green, infrared color is newly added, which makes it possible to apply the light to the security industry. Our original near-ultraviolet color "405nm" was released. As a result, almost all of the sensitivity range of general-purpose cameras is covered. Besides inspection using the light parallelism, the light can be used in various applications, such as security and communication.

Unit: mm

Model name	Irradiating color	Power Consumption	Outline drawing
IBF-LX30	R/W/B/G	IDC-700SV	1
IBF-LX40			2
IBF-LX60			3
IBF-LX30	UV (400)	IDC-700DV	1
IBF-LX40			2
IBF-LX60			3

For the applicable power supply, refer to the constant current light control power supply (p.56).

It can be connected to the power supply units except IDC (IDP, IDGA, etc.) using a resistance box (optional p.48).

represents R = red, W = white, B = blue, or G = green.

The LED used in this lighting has individual difference in the peak wavelength; therefore, even the same type products may vary slightly in color.

Comparison of light quantity by distance, between IBF vs. general light source

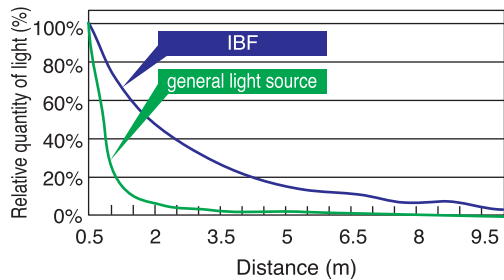

With a general light source, the light is reduced in inverse proportion to the square of distance.

When the distance is doubled, for example, the light quantity is reduced so less as 1/4, that it is not enough to irradiate at a long distance.

However, the IBF light can be irradiated at a long distance without light reduction by distance as shown in the above graph.

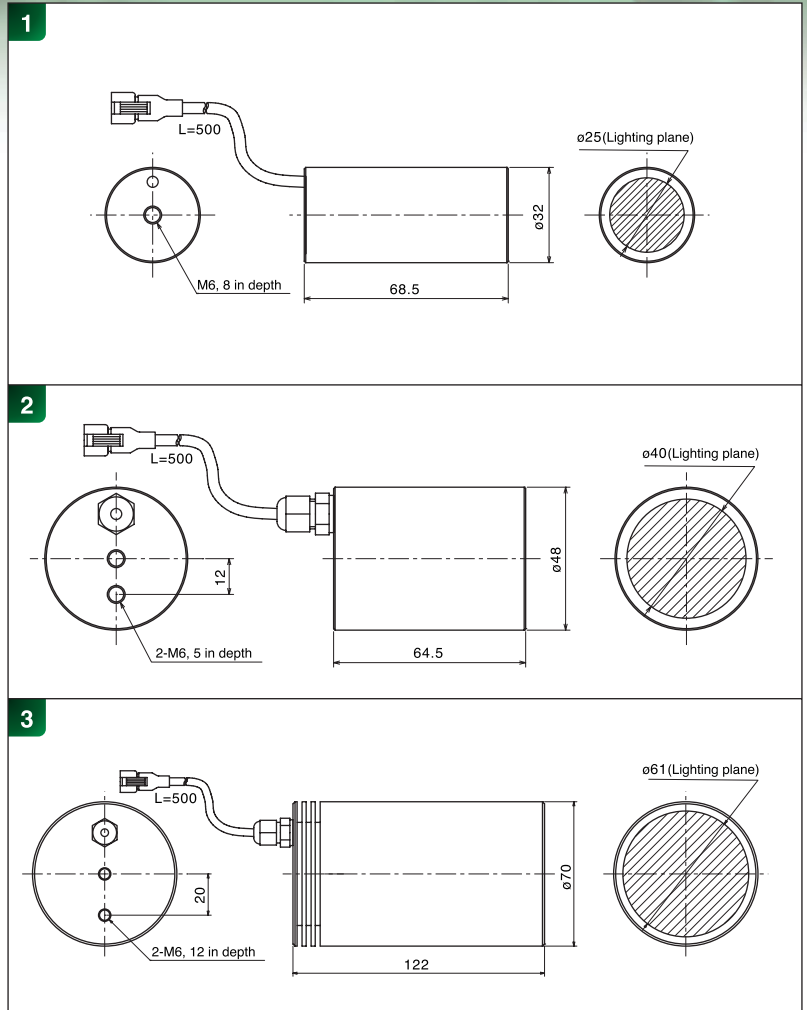

Example of use

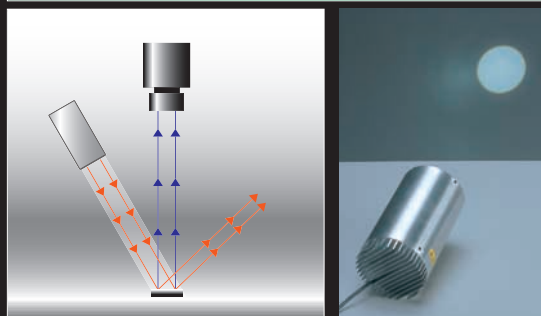

Example of the Image Photographed



When irradiating light from right above, letters printed on a chip resistance cannot be recognized due to light diffusion on a film above the work.

Work: Chip resistance in a transparent bag
Light: IDBA-C50 / 50DWS

When irradiating oblique and pseudo-parallelized light, letters printed on a chip resistance can be recognized clearly by reducing the light diffusion on a film above the work.

Work: Chip resistance in a transparent bag
Light: IBF-LX30W