



Vision processors

Matrox Odyssey eD/XD >>>

Leading-edge vision processor board.



Key features

- > x4 PCIe™ (eD) or PCI-X® (XD) long card
- > G4 PowerPC™ and proprietary ASIC combine for over 130 BOPS¹
- > over 5 GB per second of memory bandwidth
- > 512 MB of DDR SDRAM memory
- > integrated 64-bit LVDS/RS-422 frame grabber acquires up to 480 MB per second
- > up to 1 GB per second of I/O bandwidth to host PC
- > available software is sold separately and includes Matrox Imaging Library (MIL)², Matrox Odyssey Native Library (ONL), Matrox Odyssey Developer's Toolkit and Matrox Inspector³
- > host OS support for Microsoft® Windows® 2000, Windows® XP and Linux³
- > royalty-free redistribution of MIL and ONL run-time environments

Evolutionary architecture with leading-edge performance

Matrox Odyssey eD/XD is a fourth generation vision processor board that optimally combines off-the-shelf and custom technologies within an established architecture to deliver leading-edge performance and value. Designed with demanding semiconductor inspection, medical imaging, print inspection, surface inspection and signal processing applications in mind, the Matrox Odyssey eD/XD is the ideal choice for applications with data acquisition and processing rates in the order of hundreds of MBytes per second and/or where the PC is heavily loaded with other system activities.

The premier embedded microprocessor, state-of-the-art proprietary processor and router ASIC, DDR memory, and PCIe™/PCI-X® connectivity come together on the Matrox Odyssey eD/XD to provide incredible power for a single vision processor board. All this power and flexibility is accessed through an easy-to-learn programming environment compatible with Matrox Imaging's previous generation vision processor and incorporating elaborate image processing and analysis algorithms.

State-of-the-art Matrox Oasis ASIC

The Matrox Imaging designed Oasis ASIC is the pivotal component of the Matrox Odyssey eD/XD. A high-density chip, the Matrox Oasis integrates a CPU bridge, Links Controller, main memory controller and Pixel Accelerator.



Matrox Odyssey eD/XD

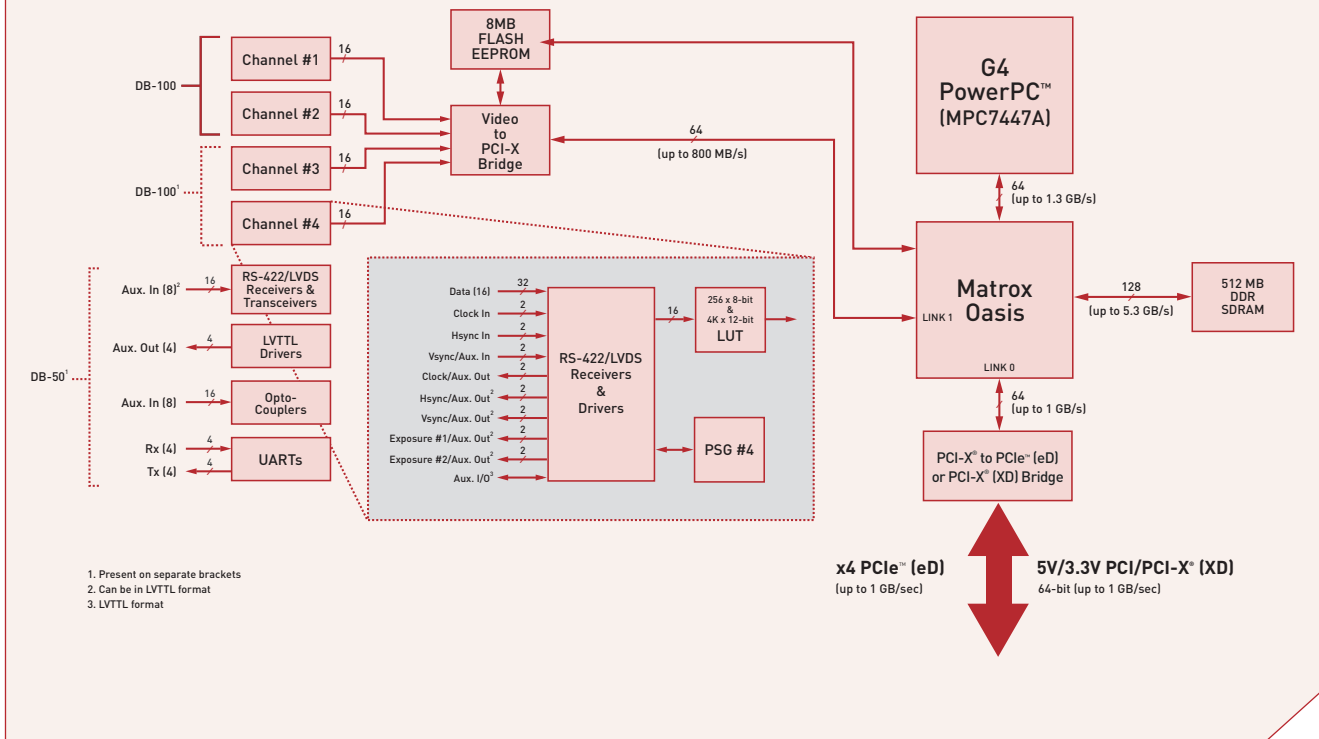

Pixel Accelerator

The Pixel Accelerator (PA) is a parallel processor core, which considerably accelerates neighborhood, point-to-point and LUT mapping operations. It consists of an array of 64 processing elements all working in parallel. Each processing element has a multiply-accumulate (MAC) unit and an arithmetic-logic unit (ALU).

The MAC unit is capable of performing a single 16-bit by 16-bit, two 8-bit by 16-bit or four 8-bit by 8-bit multiplies with 40-bit accumulation per cycle for convolution operations. The 40-bit accumulator guarantees no overflow situation for a 16 by 16 kernel with 16-bit coefficients and data. In addition, the PA architecture allows symmetrical kernels to be processed four times faster. The MAC unit is also able to perform up to four minimum or maximum operations per cycle for grayscale morphology operations.

The ALU can execute a wide variety of arithmetic and logical operations. It can be programmed to execute a sequence of 256 instructions per pixel at one instruction per cycle reducing the amount of memory accesses and further accelerating memory I/O-bound sequences. The PA can accept up to four source buffers⁴ and output to four destination buffers allowing several operations to be performed at once or in a single pass (i.e., four images can be averaged in one pass). Operating at a core frequency of 167 MHz enables the PA to carry out up to 100 BOPS¹ (i.e., process over two billion pixels per second).

Memory controller

The Matrox Oasis includes a very efficient main memory controller for managing the 128-bit wide interface to DDR SDRAM memory. Operating at 167 MHz, the DDR SDRAM memory and controller combine to deliver a memory bandwidth in excess of 5 GB per second. Such ample memory bandwidth allows the Odyssey eD/XD to comfortably handle demanding video I/O while maintaining PA performance even for memory I/O-bound operations.

Links Controller

The Links Controller (LINX) is the router that manages all data movement inside and outside the processing node, which consists of the PA, CPU and main memory. It can handle several concurrent video and message streams.

Video streams are used to transfer image data from the integrated frame grabber to the processing node and the processing node to the host PC including display. The video streams have adjustable priority levels, either above or below message streams. Video streams can be subject to various formatting operations including plane separation on input and merging on output, input cropping, input and output sub-sampling (1 to 16), and independent control of horizontal and vertical scanning direction. The latter is particularly useful for reconstructing a proper image from a camera whose readout requires multiple taps, each with different scanning directions.

Links Controller (cont.)

Message streams are for all types of inter-processor communications. The LINX handles message streams between the processing node and the host PC independently of video streams. Message passing relies on hardware-assisted mechanisms for low overheads and real-time operation. Together, the above capabilities off-load the CPU and PA from data management tasks so they can focus on image processing tasks.

freescale™ G4 PowerPC™ microprocessor

The CPU that controls activities on the Matrox Odyssey eD/XD and performs operations not accelerated by the PA is the *freescale™ G4 PowerPC™* microprocessor. The G4 combines the best features of a general purpose CPU and a DSP, and provides top performance at a given clock rate. The G4 is also backed by *freescale™*'s solid migration path for increased performance, all the while maintaining code compatibility.

The G4 incorporates a powerful 32-bit superscalar RISC and AltiVec™ technology's 128-bit vector execution unit. 512 KB of internal L2 cache helps sustain maximum processor performance. A 64-bit MPX bus offers efficient access to main memory and provides a sustained bandwidth close to its theoretical maximum of 1.3 GB per second.



AltiVec™ technology is specifically designed to meet the heavy computational requirements of applications such as video and image processing. This technology consists of a high-performance parallel processing engine for vector data. It uses the SIMD (single instruction, multiple data) model to process, in parallel, up to 16 pixels per cycle. It delivers a peak processing power of 16 billion 8-bit MACs per second or 8 billion 32-bit floating point operations per second when running at 1 GHz. Additionally, AltiVec™ technology operates concurrently with other execution units within the G4.



Choice of high-performance host bus interfaces

Four lane (x4) PCIe™ and PCI-X® are the interfaces used to connect to the host PC on the Matrox Odyssey eD and Matrox Odyssey XD boards respectively. PCIe™ is the follow-on to conventional PCI and PCI-X®. Version 1.x of PCIe™ operates at 2.5 GHz to deliver a peak bandwidth of 1GB/sec over a x4 implementation. PCI-X® is a high-performance backwards-compatible enhancement to conventional PCI. Version 1.0a of PCI-X® specifies a 64-bit physical connection running at speeds of up to 133 MHz resulting in a peak bandwidth of up to 1 GB per second.

Flash EEPROM for full autonomy

Matrox Odyssey eD/XD has a flash EEPROM that stores the G4 PowerPC™ boot sequence, system initialization parameters and a debugging utility. It can also be used to store the operating system and application program in order to implement a truly autonomous system from power-up.

Integrated 64-bit LVDS/RS-422 frame grabber

Designed to support legacy scientific, industrial and medical imaging devices, the integrated LVDS/RS-422 frame grabber features four completely independent 16-bit wide inputs. These inputs can be configured to acquire from two, four and eight-tap

monochrome sources as well as RGB sources. The integrated LVDS/RS-422 frame grabber also includes an internal video generator for troubleshooting installation and operation.

All-encompassing programming environment

The Matrox Odyssey eD/XD offers the developer a choice of application programming interfaces (APIs) and programming models. Application developers can program the board using the Matrox Imaging Library or Matrox Odyssey Native Library, each with royalty-free run-time environments². The application program can run on the host PC to remotely control the Matrox Odyssey eD/XD (i.e., options A and B) or it can be made to run entirely on the Matrox Odyssey eD/XD (i.e., options C and D).

Matrox Imaging Library (MIL)

MIL is a complete and easy-to-use programming library for image capture, processing, analysis, display and archiving that supports the complete line of existing and future Matrox Imaging hardware. MIL's field-proven processing and analysis functions include point-to-point, statistics, filtering, morphology, geometric transformations, FFT, segmentation, edge extraction and analysis, pattern recognition, blob analysis, measurement, character recognition, 1D and 2D code reading, calibration, and JPEG/JPEG2000 image compression. These functions run on the Matrox Odyssey eD/XD and are fully optimized for the G4 PowerPC™ and PA.

MIL for the Matrox Odyssey eD/XD is carefully tuned to exhibit low function call overheads, maximizing application efficiency and performance. MIL provides transparent image display management with automatic tracking and updating of image display windows at live video rates. MIL also allows for image display in a user-specified window. In addition, MIL supports live display of multiple video streams using multiple independent windows or a single mosaic window. Moreover, MIL provides non-destructive graphics overlay, suppression of tearing artifacts and filling the display area at live video rates. All of these features are performed with little or no host CPU intervention when using the appropriate graphics hardware. Refer to the MIL datasheet for more information.

Odyssey Native Library (ONL)

ONL is an easy-to-use programming library specific to the Matrox Odyssey family of vision processor boards. The programming interface is compatible with the Matrox Genesis family of vision processor boards. Aside from video capture and system control, ONL includes functions for image processing, normalized grayscale correlation-based pattern recognition, blob analysis and JPEG compression. These functions are fully optimized to exploit the power of the G4 PowerPC™ and PA. ONL functions exhibit the lowest call overheads.

Programming models

Application programs for the Matrox Odyssey eD/XD can run in a host-driven or fully embedded mode. In the host-driven mode, the application program runs on the CPU of the host PC and remotely sends commands to the Matrox Odyssey eD/XD for execution. The host-driven mode is the easiest to implement but it may be subject to the lack of determinism of the host PC platform. In the fully embedded mode, the application program runs directly on the G4 PowerPC™. The application program has little or no interaction with the host PC platform, ensuring deterministic behavior. Using the fully embedded mode requires the Matrox Odyssey Developer's Toolkit.

» Software environment

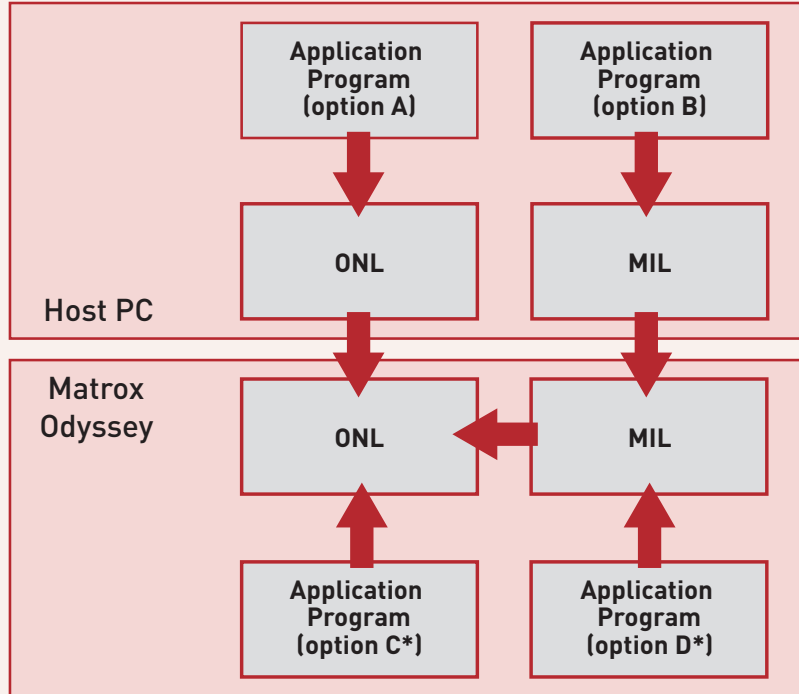

Note: Arrows indicate direction of function call.

*Requires DTK package

Matrox Odyssey Developer's Toolkit

The Matrox Odyssey Developer's Toolkit (DTK) allows a developer to extract the full power of the Matrox Odyssey eD/XD. In addition to giving the means to run a MIL and/or ONL-based application program directly on the G4 PowerPC™, the Matrox Odyssey DTK lets a developer further optimize an algorithm by merging ONL functions to reduce main memory I/O bottlenecks.

The Matrox Odyssey DTK also allows developers to write custom G4 PowerPC™ and PA functions. Custom G4 PowerPC™ code is written entirely in C/C++ including optimizations for AltiVec™ technology. AltiVec™ technology is programmed through C language extensions and intrinsic functions. No exotic assembly code is required. Custom PA code is done through a low-level API and pseudo-assembly language. Refer to the Matrox Odyssey Developer's Toolkit datasheet for more information.

Utilities

Bundled with the MIL and ONL software development kit is the Matrox Intellicam camera configuration utility. Matrox Intellicam is a Windows®-based program that lets users interactively configure the frame grabber modules to capture from a variety of video sources. Also included is an interactive system configuration and debugging utility that incorporates a memory and command viewer, performance monitor and system diagnostic tool.

Operating system support

Supported host environments for the Matrox Odyssey eD/XD are Microsoft® Windows® 2000, Windows® XP and Linux³. The G4 PowerPC™ runs an off-the-shelf RTOS with a very small footprint and fast response to task switches and interrupts.

Specifications

Hardware

- x4 PCIe™ long card or PCI/PCI-X® long card with universal 64-bit card edge connector (64-bit 33/66 MHz 5/3.3V PCI and 64-bit 66/100/133 MHz PCI-X)
- 1 GHz MPC7447A (167 MHz MPX bus)
- 512 MB of 167 MHz DDR SDRAM main memory
- 16 MB flash EEPROM
- four independent video inputs with
 - 16-bit wide LVDS or RS-422 interface
 - acquisition rates up to 60 MHz for LVDS and 32 MHz for RS-422
 - 256 x 8-bit and 4K x 12-bit LUTs
 - LVDS/RS-422 clock, hsync and vsync/auxiliary inputs
 - five LVDS/RS-422 configurable auxiliary outputs (four can be LVTTTL)
 - three LVTTTL configurable auxiliary I/Os
 - serial communication port
- can be configured to acquire from
 - four single-tap 8 to 16-bit or dual-tap 8-bit monochrome sources
 - two dual-tap 10 to 16-bit or four-tap 8-bit monochrome sources
 - single four-tap 10 to 16-bit or eight-tap 8-bit monochrome source
 - two 8-bit RGB sources
 - single 10 to 16-bit RGB source
- supports frame and line-scan video sources
- eight LVDS/RS-422 configurable auxiliary inputs (two can be LVTTTL)
- four LVDS/RS-422 configurable auxiliary outputs
- eight opto-isolated configurable auxiliary inputs
- internal video generator for diagnostics

Dimensions and environmental information

- 31.4 L x 10.7 H x 1.73 W cm (12.4" x 4.2" x 0.68") from bottom edge of gold finger to top edge of board, and without bracket and retainer
- power consumption (typical): 5.69A @ 5V or 28.45W total
- operating temperature: 0° C to 55° C (32° F to 131° F)
- ventilation requirements: 100 LFM (linear feet per minute) over board(s)
- relative humidity: up to 95% (non-condensing)
- FCC class B
- CE class B
- RoHS-compliant

Software Environment

- host driver for Microsoft® Windows® 2000, Windows® XP and Linux³
- application (control) program running under Windows® on host PC developed using
 - MIL ('C' DLLs) with Microsoft® Visual C++®.NET 2003
 - ActiveMIL (ActiveX controls) with Microsoft® Visual Basic®.NET 2003 or Visual C++®.NET 2003
 - ONL ('C' DLLs) with Microsoft® Visual C++® .NET 2003
- application (control) program running under Linux³ on host PC developed using ONL with GNU Compiler Collection (GCC)
- application program running on board developed using Matrox Odyssey DTK (MIL and/or ONL) with Metrowerks® CodeWarrior® for PowerPC™ Embedded Systems

Ordering Information

Boards

Part number	Description
0 10G 5M QDL or R*	PCI-X® vision processor board with 1 GHz MPC7447A, 512 MB DDR SDRAM, integrated 64-bit LVDS or RS-422 frame grabber and cable adapter board.
0 10G 5M QDL or R E*	x4 PCIe™ vision processor board with 1 GHz MPC7447A, 512 MB DDR SDRAM, integrated 64-bit LVDS or RS-422 frame grabber and cable adapter board.

Software

Part number	Description
MIL ONL WIN SDK	Matrox Odyssey Software Development Toolkit (SDK) under Windows®. Includes CD with Matrox Imaging Library (MIL) for Odyssey², Odyssey Native Library (ONL), Intellicam and online/printed documentation. Note: For creating an application program to control board from host PC.
MIL ONL WIN DTK	Matrox Odyssey Developer's Toolkit (DTK) under Windows®. Includes CD with MIL for Odyssey², ONL, MIL DTK, ONL DTK, Intellicam and online/printed documentation. Note: For creating an application program running directly on board.
MIL ONL LNX SDK³	Matrox Odyssey Software Development Toolkit (SDK) under Linux³. Includes CD with Matrox Imaging Library (MIL) for Odyssey², Odyssey Native Library (ONL) and online/printed documentation. Note: For creating an application program to control board from host PC.

Software Maintenance Program

Included in the original purchase price of the Matrox Odyssey SDK and DTK, it entitles registered users to one year of technical support and free updates.

Part number	Description
MIL ONL MAINT	One year program extension

Cables

Part number	Description
DBHD100-TO-OPEN	3 m (10') high density DB-100 to open end cable for LVDS/RS-422 frame grabber module (requires customization).

Notes:

1. Billion operations per second.
2. MIL for Odyssey includes MIL for IA32 (host PC), which requires an additional development or run-time license.
3. Contact local representative or Matrox Imaging Sales for availability.
4. Only one source buffer for MAC unit.

Freescape and AltiVec technology are trademarks of Freescape Semiconductor, Inc. PowerPC is a trademark of International Business Machines Corporation, used under license therefrom.

Corporate headquarters:

Matrox Electronic Systems Ltd.
1055 St. Regis Blvd.
Dorval, Quebec H9P 2T4
Canada
Tel: +1 (514) 685-2630
Fax: +1 (514) 822-6273

For more information, please call: 1-800-804-6243 (toll free in North America) or (514) 822-6020 or e-mail: imaging.info@matrox.com or <http://www.matrox.com/imaging>

matrox

All trademarks by their respective owners are hereby acknowledged. Matrox Electronic Systems, Ltd. reserves the right to make changes in specifications at any time and without notice. The information furnished by Matrox Electronic Systems, Ltd. is believed to be accurate and reliable. However, no responsibility license is granted under any patents or patent rights of Matrox Electronic Systems, Ltd. Windows and Microsoft are trademarks of Microsoft Corporation. MMX and the MMX logo are registered trademarks of Intel Corporation. Printed in Canada, 2007-11-19. **51E-5374-B**