



CCD Camera
GiantDragon B/W Series
CSGV90BC3 CSGX36BC3
CSGS20BC2 CSGU15BC18
CSGS15BC23
Specifications

Contents

CASES FOR INDEMNITY (LIMITED WARRANTY)

RESTRICTION FOR USE

Notes on using this product

1. Overview	1
2. Features	1
3. Configuration	2
4. Optional part	2
5. Functions	2
6. Specifications	5
7. Timing chart	12
8. Guarantee	14
9. Repair	14
10. Outline Drawing	15

TOSHIBA TELI CORPORATION

Printed on recycled paper

D4153486A

CASES FOR INDEMNITY (LIMITED WARRANTY)

We shall be exempted from taking responsibility and held harmless for damage or losses incurred by the user in the following cases.

- In the case damage or losses are caused by fire, earthquake, or other acts of God, acts by a third party, deliberate or accidental misuse by the user, or use under extreme operating conditions.
 - In the case of indirect, additional, consequential damages (loss of business interests, suspension of business activities) are incurred as result of malfunction or non-function of the equipment, we shall be exempted from responsibility for such damages.
 - In the case damage or losses are caused by failure to observe the information contained in the instructions in this instruction manual and specifications.
 - In the case damage or losses are caused by use contrary to the instructions in this instruction manual and specifications.
 - In the case damage or losses are caused by malfunction or other problems resulting from use of equipment or software that is not specified.
 - In the case damage or losses are caused by repair or modification conducted by the customer or any unauthorized third party (such as an unauthorized service representative).
 - Expenses we bear on this product shall be limited to the individual price of the product.
-

RESTRICTION FOR USE

- Should the equipment be used in the following conditions or environments, give consideration to safety measures and inform us of such usage:
 1. Use of the equipment in the conditions or environment contrary to those specified, or use outdoors.
 2. Use of the equipment in applications expected to cause potential hazard to people or property, which require special safety measures to be adopted.

 - This product can be used under diverse operating conditions. Determination of applicability of equipment or devices concerned shall be determined after analysis or testing as necessary by the designer of such equipment or devices, or personnel related to the specifications. Such designer or personnel shall assure the performance and safety of the equipment or devices.

 - This product is not designed or manufactured to be used for control of equipment directly concerned with human life (*1) or equipment relating to maintenance of public services/functions involving factors of safety (*2). Therefore, the product shall not be used for such applications.
 - (*1): Equipment directly concerned with human life refers to.
 - Medical equipment such as life-support systems, equipment for operating theaters.
 - Exhaust control equipment for exhaust gases such as toxic fumes or smoke.
 - Equipment mandatory to be installed by various laws and regulations such as the Fire Act or Building Standard Law
 - Equipment related to the above
 - (*2): Equipment relating to maintenance of public services/functions involving factors of safety refers to.
 - Traffic control systems for air transportation, railways, roads, or marine transportation
 - Equipment for nuclear power generation
 - Equipment related to the above
-

Notes on using this product

- **Handle carefully**

Do not drop the equipment or allow it to be subject to strong impact or vibration, as such action may cause malfunctions. Further, do not damage the connection cable, since this may cause wire breakage.

- **Environmental operating conditions**

Do not use the product in locations where the ambient temperature or humidity exceeds the specifications. Otherwise, image quality may be degraded or internal components may be adversely affected. In particular, do not use the product in areas exposed to direct sunlight. Moreover, during shooting under high temperatures, vertical stripes or white spots (noise) may be produced, depending on the subject or camera conditions (such as increased gain). However, such phenomena are not malfunctions.

- **Regarding a lens mount**

Depending on the lens you use, the performance of the camera may not be brought out fully due to the deterioration in resolution and brightness in the peripheral area, occurrence of a ghost, aberration and others. When you check the combination between the lens and camera, be sure to use the lens you actually use.

As for the C-mount lens used combining this camera, the projection distance from bottom of the screw should use 9.4mm or less.

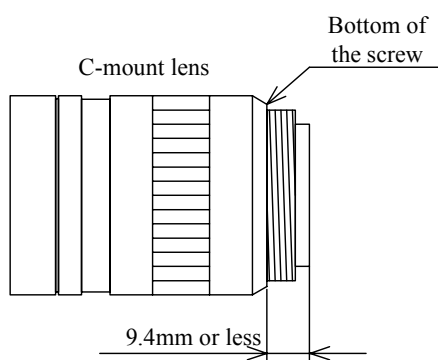

- **Check a combination with the lens**

Depending on the lens and lighting you use, an image is reflected as a ghost in the imaging area. However, this is not because of a fault of the camera.

In addition, depending on the lens you use, the performance of the camera may not be brought out fully due to deterioration in resolution and brightness in the peripheral area, aberration and others.

Be sure to check a combination with the camera by using the lens and lightning you actually use.

When installing a lens in the camera, make sure carefully that it is not tilted.

In addition, use a mounting screw free from defects and dirt. Otherwise, the camera may be unable to be removed.

- **Do not shoot under intense light**

Avoid intense light such as spot lights on part of the screen because it may cause blooming or smears. If intense light falls on the screen, vertical stripes may appear on the screen, but this is not a malfunction.

- **Occurrence of moiré**

If you shoot thin stripe patterns, moiré patterns (interference fringes) may appear. This is not a malfunction.

- **Occurrence of noise on the screen**

If an intense magnetic or electromagnetic field is generated near the camera or connection cable, noise may be generated on the screen. If this occurs, move the camera or the cable.

- **Handling of the protective cap**

If the camera is not in use, attach the lens cap to the camera to protect the image pickup surface.

- **If the equipment is not to be used for a long duration**

Turn off power to the camera for safety.

- **Maintenance**

Turn off power to the equipment and wipe it with a dry cloth.

If it becomes severely contaminated, gently wipe the affected areas with a soft cloth dampened with diluted neutral detergent. Never use alcohol, benzene, thinner, or other chemicals because such chemicals may damage or discolor the paint and indications.

If the image pickup surface becomes dusty, contaminated, or scratched, consult your sales representative.

- **Disposal**

When disposing of the camera, it may be necessary to disassemble it into separate parts, in accordance with the laws and regulations of your country and/or municipality concerning environmental contamination.

1. Overview

This GiantDragon B/W series is an integrated-(one-body)-type monochrome camera that adopts all pixel data readout inter line CCD. There are 4 models according to the sensor type. These are CSGV90BC3 (VGA), CSGX36BC3 (XGA), CS GS20BC2 (SXGA: 1/2 type), CS GU15BC18 (UXGA), and CS GS15BC23 (SXGA: 2/3 type). For video output and camera control, the Gigabit Ethernet[®]* interface standard “IEEE802.3ab” is adopted for high transfer rate, and it is easy to integrate into industrial equipment.

* Ethernet[®] is a registered trademark of XEROX Corporation.

2. Features

(1) High frame rate and high resolution

Supported high frame rate CSGV90BC3 (90fps/VGA), CSGX36BC3 (36fps/XGA), CS GS20BC2 (20fps/SXGA: 1/2 type), CS GU15BC18 (15fps/UXGA), and CS GS15BC23 (15fps/SXGA: 2/3 type).

(2) All pixel readout

All pixel signals (in the effective area) are output in one frame processing.

(3) Full frame shutter

Since all pixels are output even by shutter operation, high resolution can be achieved, without deteriorating the vertical resolution.

(4) Square grids

The CCD pixels arrayed in square grids facilitates computation for image processing.

(5) Gigabit Ethernet interface

Performs video output and camera control via the Gigabit Ethernet standard IEEE802.3ab interface.

Data transfer is at 1Gbps that can output uncompressed video data of high frame rate.

(6) GigEVision Ver 1.0 conformity

This product is based on GigEVision Camera Interface Standard for Machine Vision Ver 1.0 that is industrial camera standard. Therefore, control of this camera is easy.

(7) GenICam Ver 1.0 conformity

This product is based on GenICam Generic Interface for Cameras Ver 1.0 that is industrial camera standard. Therefore, control of this camera is easy.

(6) Scalable mode

This camera has the scalable mode that can read out defined area of the screen. Only continuous rectangle units can be selected, concave or convex shape cannot be selected.

- Window size: $\{A \times m(H)\} \times \{B \times n(V)\}$

* A and B are minimum unit size.

* m, n=integer, and the image of maximum unit size or less can be selected.

* Only one window can be selected.

	CSGV90BC3	CSGX36BC3	CSGS20BC2	CSGU15BC18	CSGS15BC23
Minimum unit size (H) x (V)	160 x 120	256 x 192	160 x 120	200 x 150	170 x 128
Maximum unit size (H) x (V)	640 x 480	1024 x 768	1280 x 960	1600 x 1200	1360 x 1024

- Start address: $\{32 \times i(H)\} \times \{24 \times j(V)\}$

* i, j=integer, and the image of maximum unit size or less can be selected.

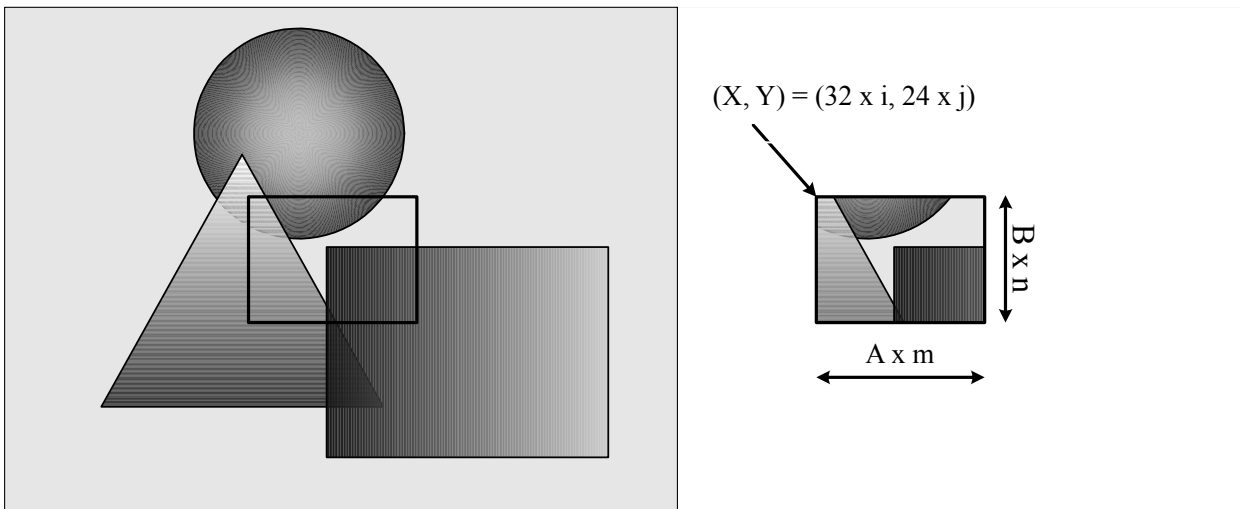

In the scalable mode, this camera reads out only the necessary portions at the standard speed while it scans through other unnecessary portions at high speed, so the trigger interval can be shorter if the vertical cutout width is small. However, the trigger interval cannot be short in the horizontal direction even if the cutout width is small due to the operation mechanism of the CCD sensor.

Notes on scalable mode:

White lines may occur in the upper portions of the screen when strong light exists in a wide area during the scalable mode. This is not a malfunction. If white lines occur, adjust the amount of incident light using the lens.

6. Specifications

[Electrical specification]

(1) Imager

all-pixel-data-readout interline transfer CCD

	CSGV90BC3	CSGX36BC3	CSGS20BC2	CSGU15BC18	CSGS15BC23
Number of total pixels (H) x (V)	692 x 504	1077 x 788	1434 x 1050	1688 x 1248	1434 x 1050
Number of effective pixels (H) x (V)	659 x 494	1034 x 779	1392 x 1040	1628 x 1236	1392 x 1040
Number of Video out pixels (H) x (V)	640 x 480	1024 x 768	1280 x 960	1600 x 1200	1360 x 1024
Scanning area (H) x (V)	4.88 x 3.66mm ² (1/3 type)	4.81 x 3.62mm ² (1/3 type)	6.47 x 4.84mm ² (1/2 type)	7.16 x 5.44mm ² (1/1.8 type)	8.98 x 6.71mm ² (2/3type)
Pixel size (H) x (V)	7.4 x 7.4μm ²	4.65 x 4.65μm ²	4.65 x 4.65μm ²	4.40 x 4.40μm ²	6.45 x 6.45μm ²

(2) Scan method

Non-interlace

(3) Synchronization method

Internal synchronization

(4) Aspect ratio

4:3

(5) Sensitivity

	CSGV90BC3	CSGX36BC3	CSGS20BC2	CSGU15BC18	CSGS15BC23
Standard subject illuminance	600 lx	800 lx	500 lx	400 lx	400 lx
	F5.6	F5.6	F5.6	F8	F11
	1/90s	1/36s	1/20s	1/15s	1/15s

(6) Minimum subject illuminance (F1.4, GAIN Maximum, video level 50 %)

	CSGV90BC3	CSGX36BC3	CSGS20BC2	CSGU15BC18	CSGS15BC23
Minimum subject illuminance	5 lx	7 lx	4 lx	2 lx	1.5 lx

(7) Gain

0 to +12 dB (91step)

initial factory setting: 0 dB

(8) Gamma correction

OFF (γ= 1.0 fixed)

(9) Setup-level

6.3 to 25 % (192step)

initial factory setting: 6.3%

(10) Power supply

DC 12V ±10% (ripple 100 mV(p-p) or less)

(11) Power consumption

3.5W (Maximum)

[Internal sync signal specification]

(1) Base clock frequency

36.0000 MHz +/- 100ppm

[Machine externals specification]

- (1) Dimensions 44mm(W) x 29mm(H) x 70mm(D) (Not including protrusion)
- (2) Mass Approximately 120g
- (3) Lens mount C-mount
- (4) Flange back it is not possible to adjust it: 17.526mm
- (5) Camera body grounding: insulation status
Conductive between circuit GND and camera body.

[Operating ambient conditions]

- (1) Ambient conditions
 - Performance assurance Temperature: 0 - 40°C, Humidity: 10 - 90% (no condensation)
 - Operating assurance Temperature: -5 - 45°C, Humidity: 90% or less (no condensation)
 - Storage assurance Temperature: -20 - 60°C, Humidity: 90% or less (no condensation)
- (2) EMC conditions (Electro-Magnetic Compatibility)
 - EMI (Electro-Magnetic interference)
 - EN61000-6-4 conformity
 - FCC part15 Subpart B class A conformity
 - EMS (Electro-Magnetic susceptibility)
 - EN61000-6-2 conformity

Notes on Conformity of the EMC:

About the conformity of the EMC standard of this machine, it has guaranteed in the conditions combined with the option part of 4th clause.

When used combining parts other than specification of our company, I ask you to have final EMC conformity checked of a visitor with a machine and the whole equipment.

[Connector pin assignment]

- (1) Gigabit Ethernet interface connector
 - Connector model (Camera side) P65-P01-19V8 (Supplied by SpeedTech Corp.)
 - Pin assignment

Pin No.	I/O	Function
1	I/O	BI_DA+
2	I/O	BI_DA-
3	I/O	BI_DB+
4	I/O	BI_DC+
5	I/O	BI_DC-
6	I/O	BI_DB-
7	I/O	BI_DD+
8	I/O	BI_DD-

(2) Connector for Power Supply and trigger signal input

- Connector (Camera side)

HR10A-7R-6PB(73)

(Supplied by HIROSE ELECTRIC CO., LTD.)

- Plug (Cable side)

HR10A-7P-6S(73)

(Supplied by HIROSE ELECTRIC CO., LTD.)

* This camera cable is not an accessory of this product.

- Pin assignment

Pin No.	Signal Name [Standard specification]
1	BUSY_OUT
2	GND
3	GND
4	TRIG_IN
5	EXPOSE_OUT
6	+12V

Pin number assignment

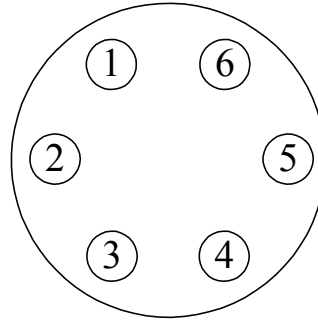

* Above figure is connector view from insert side.

[Typical spectral response]

The lens characteristics and light source characteristics is not reflected in table.

<CSGV90BC3>

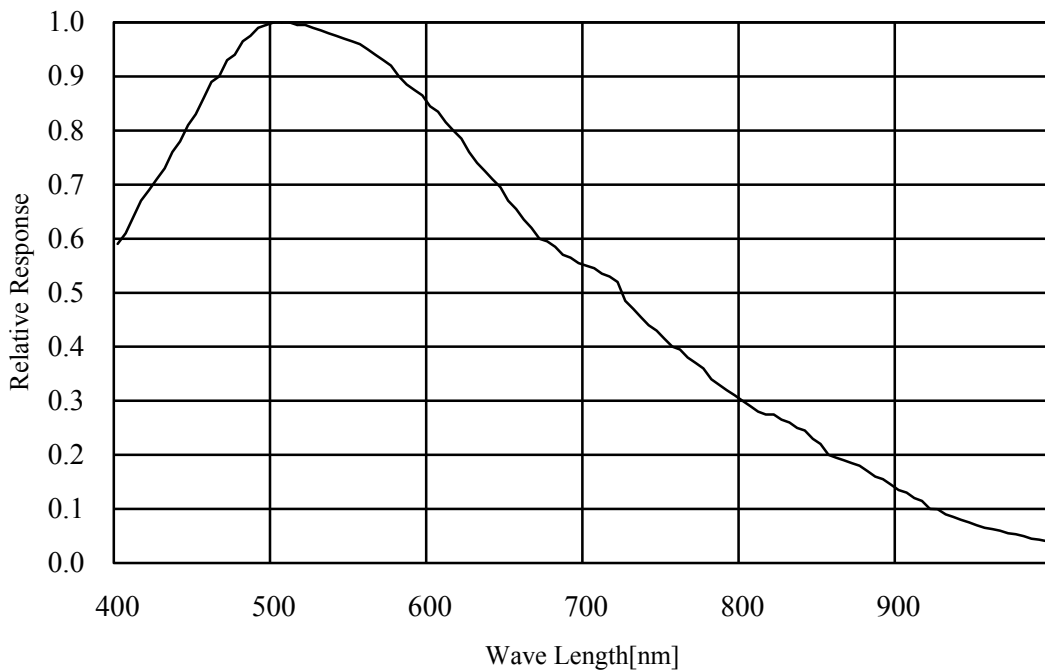

<CSGX36BC3>

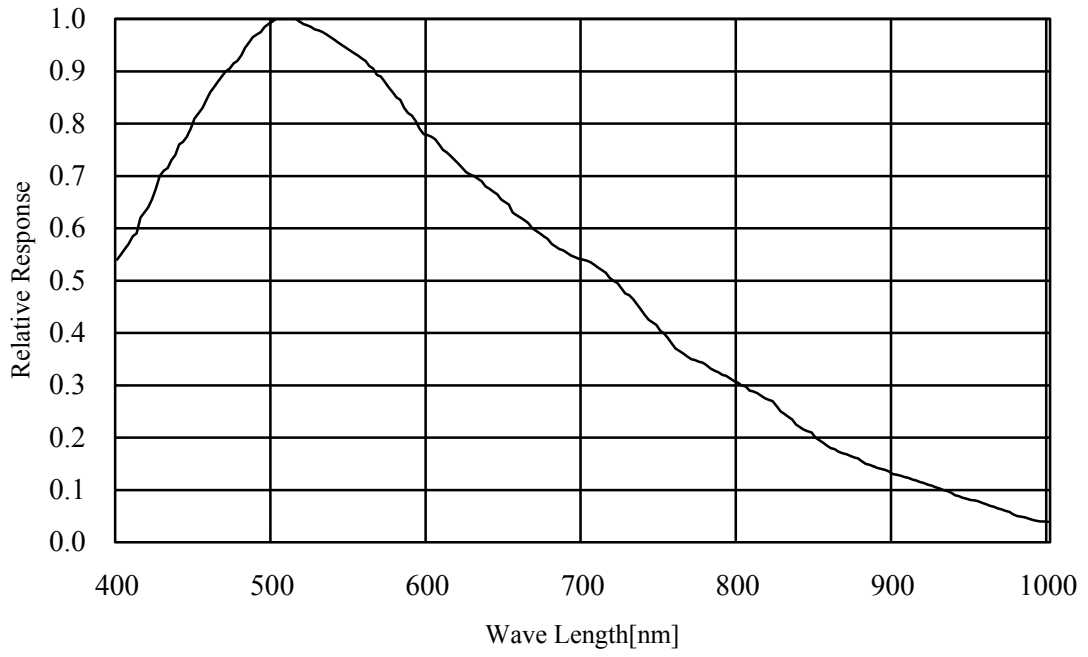

<CSGS20BC2>

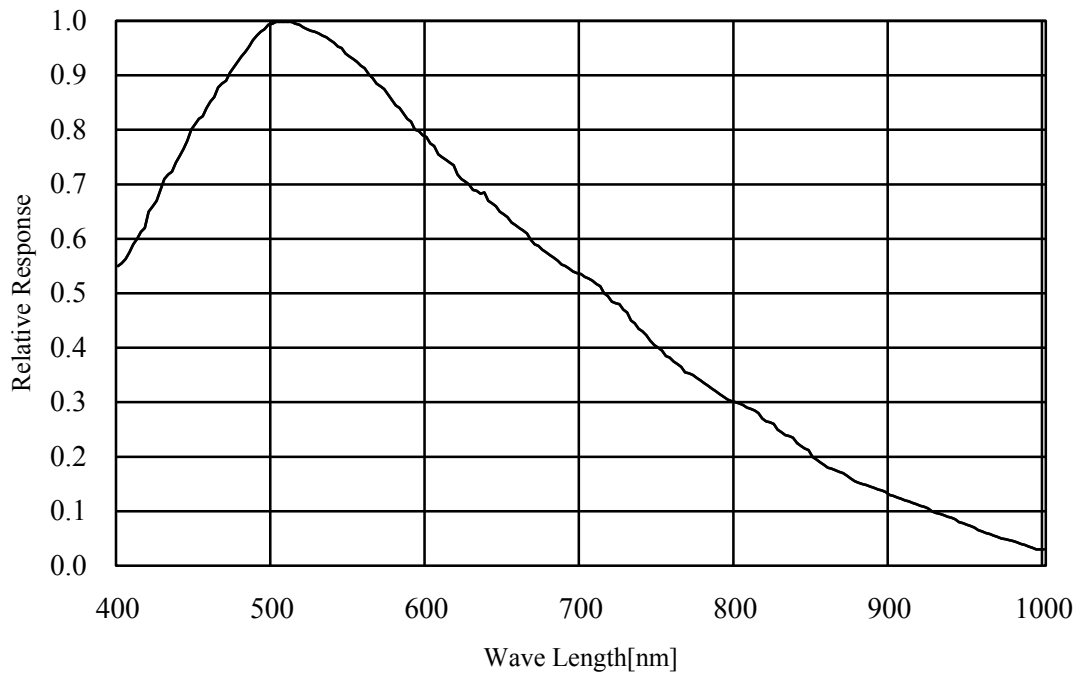

<CSGU15BC18>

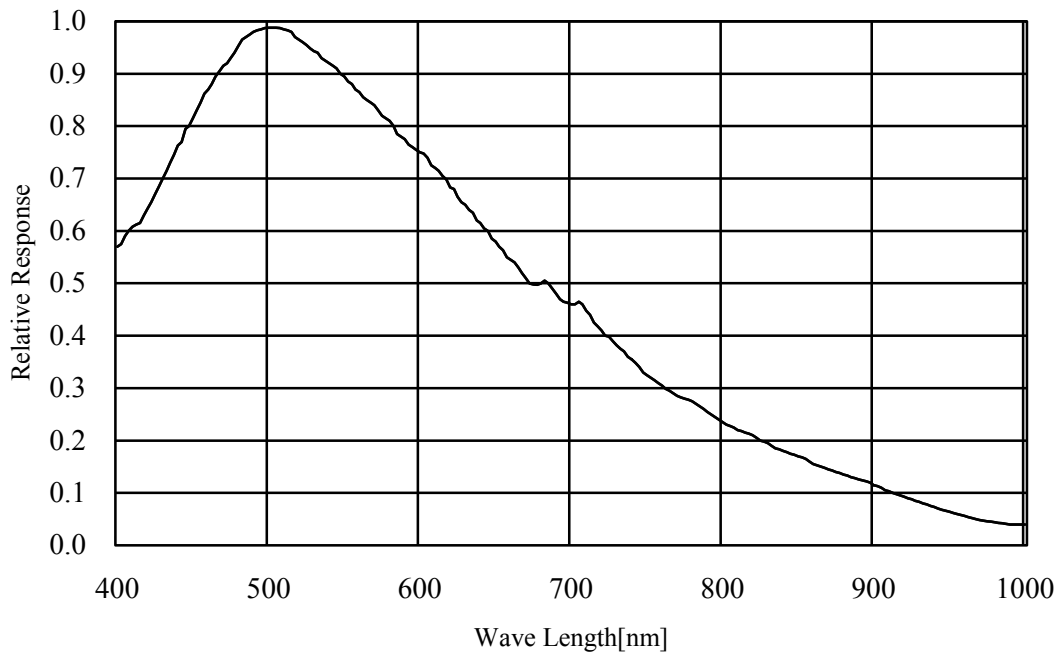

<CSGS15BC23>

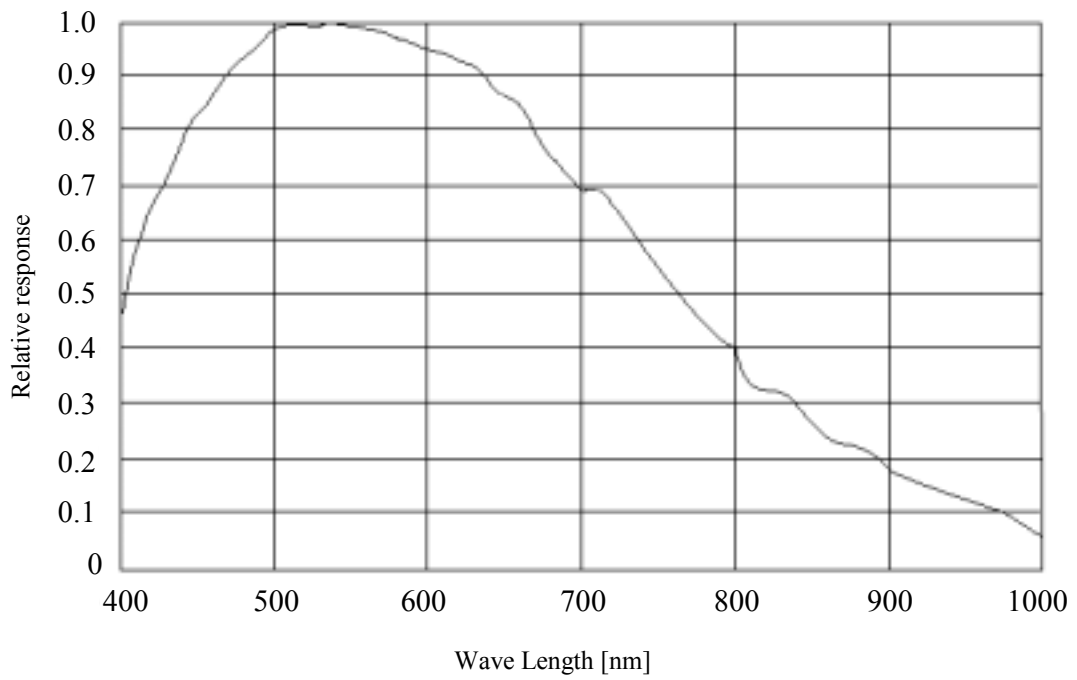

7. Timing chart

Image data outputs of this camera series are transferred with the UDP protocol of Gigabit Ethernet. Timing numerical value below is prescribed by absolute prerequisite that GiantDragon series use transmission band without restriction of other node. When there is a node transferring with GiantDragon concerned, it is not same the numerical value prescribed below.

(1) In the normal shutter mode

Video format: MONO 8, all pixel readout

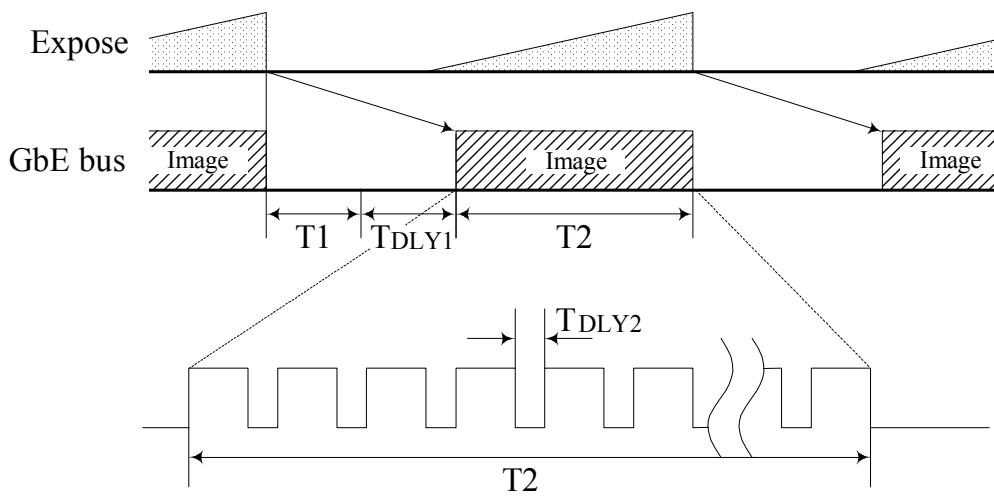

Model name	T1 [ms]	T2 [ms]	Frame rate [ms]
CSGV90BC3	0.5	2.8	11.1
CSGX36BC3	0.5	6.7	27.8
CSGS20BC2	1.0	10.4	50.0
CSGU15BC18	1.0	16.0	66.7
CSGS15BC23	1.0	11.7	66.7

* T1 is the maximum value, and T2 (GVSP_FRAME_RATE) is the minimum value.

* Frame rate is maximum speed.

* At the setting the GVSP_SIZE (SCPS_x) = 1500 byte / packet.

(T2 is changed by GVSP_SIZE (SCPS_x).

* Set the value that T_{DLY1} (GVSP_BLOCK_START_DELAY) to satisfy the next numerical formula;

$$T1 + T_{DLY1} + T2 \geq \text{Frame rate}$$

(2) In the random trigger shutter mode

- When fixed mode (Video format: MONO 8, all pixel readout);

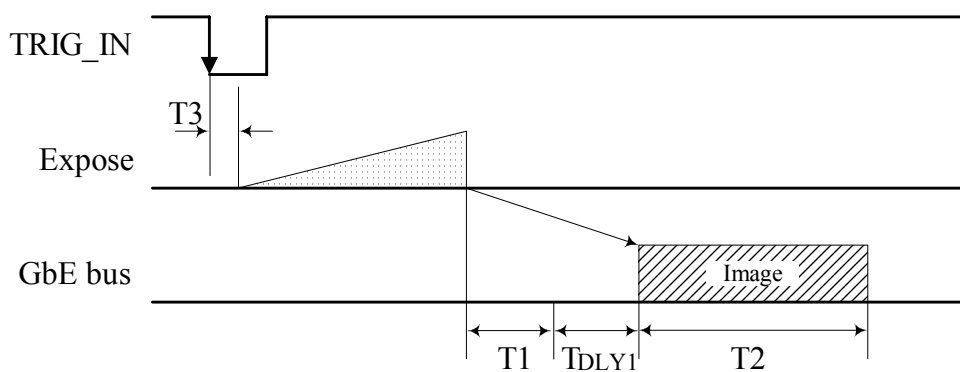

- When pulse width mode (Video format: MONO 8, all pixel readout);

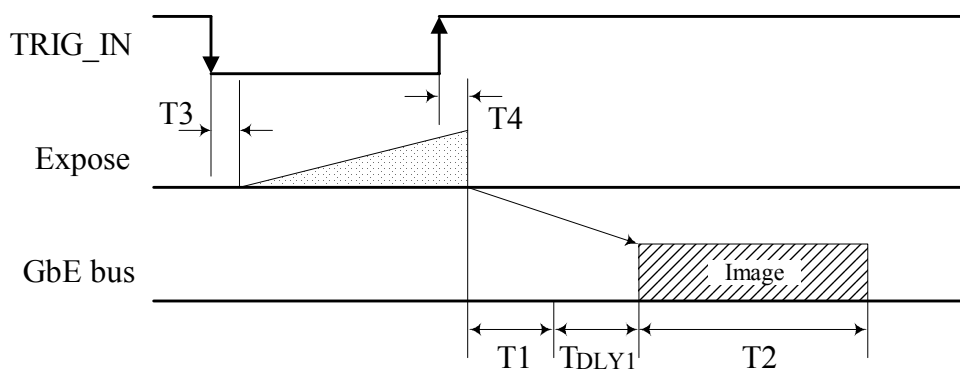

Model name	T3 [us]	T4 [us]
CSGV90BC3	0.9	2.8
CSGX36BC3	1.5	25.2
CSGS20BC2	3.4	5.1
CSGU15BC18	1.9	7.5
CSGS15BC23	3.8	23.8

* The value of T1 and T2 are the same as the value at the of the normal shutter setting.

8. Guarantee

The term of a guarantee is 12 months after the product delivery.

If by any chance trouble by responsibility of our company occurs before an above period, TELI repairs it free of charge according to a repair rule of Clause 9.

During terms of a guarantee, when the trouble cause is the case of below, TELI charges the repair costs.

- Troubles and the damages that causes by misuse, unsuitable repair or remodeling.
- Distribution hazards like drops and vibrations after purchase. Troubles and damages by transportation.
- Troubles and damages by fire, natural calamity (earthquake, storm and flood damage, thunderbolt), damages from salty breeze, gas harm, abnormal voltage.

9. Repair

(1) Condition for repair

Basically, has to return it to our company when the user requests us to repair product.

Beside that, customer should pay these expenses (travel expenses, camera disassembly technology costs) of both customer and end user. Also customer should pay in themselves costs for return camera to us.

(2) The period of repairing product

- Repair free of charge Refer to Clause 8.
- Charged repair Basically, repair period is 7 years after the last production end of products.

10. Outline Drawing

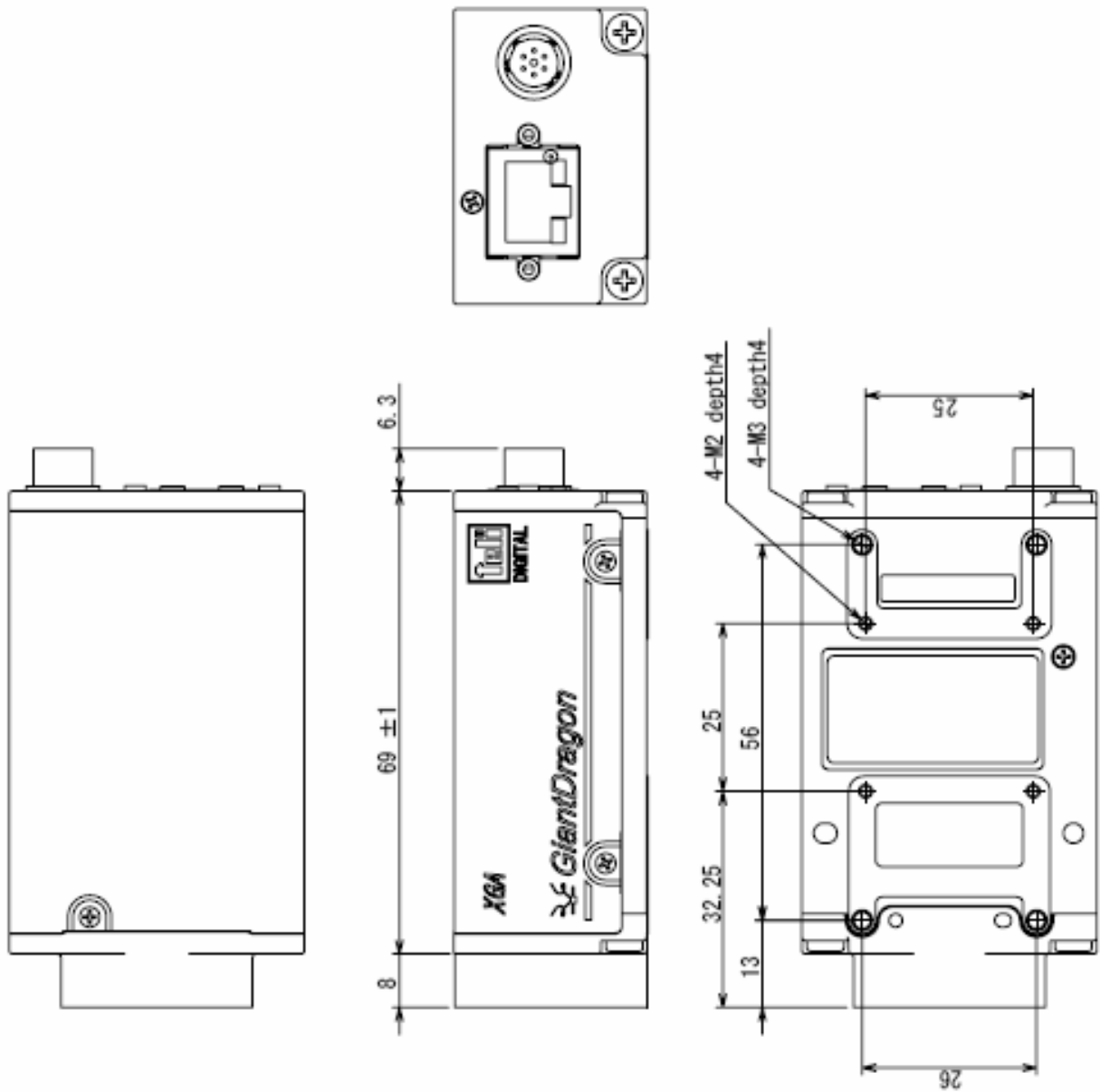

Specification
Material : Aluminium alloy
Surface : Kation coating (Black)
(Cover): Leather-Satin print (Black)
 [Unit : mm]



TOSHIBA TELI CORPORATION

Head Office: 7-1, 4 chome, Asahigaoka, Hino-shi, Tokyo, 191-0065, Japan

(Overseas Sales Department)

Phone : +81-42-589-8771

Fax : +81-42-589-8774

URL : <http://www.toshiba-teli.co.jp>

Distributor

- This product must be classified for disposal according to the laws of each country and municipal laws.
 - Information contained in this document is subject to change without prior notice.
-